

EZ METER

Watt-hour Meter Operation & Installation



CAUTIONS

Serious injury can result from electric shock. Be sure to turn off the power before installing or servicing any meter.

Fire can result from loose electrical connections. Ensure that all connections are secure.

A loose or improperly connected neutral can damage equipment and cause fires. Most meters that count faster than they should are connected to a bad neutral.

These meters should only be installed experienced electricians. If you do not fully understand these instructions, call the factory at 800-824-9696 for clarification.

In most localities, a permit and inspection is required to install the meters.

Legends

These symbols appear on meter labels.

- 1 Caution, risk of Danger
- G Equipment protected throughout by double insulation
- H Alternating Current

Safety Certification

Most 120 volt to neutral EZMeters come in a CSA International certified package that includes the electronics module, counter, current transformers and enclosure. The enclosure may hold from one to 24 meters. This mark is the legal equivalent of a UL Listing mark and is valid in the United States and Canada. The applicable standards are UL 61010-1, CA/CSA-C22.2 No. 61010-1 and ISA-82.02.01 (IEC 61010-1 MOD). The certification is for pollution degree 2 and installation category II. Meters with split-core CTs have not been tested or certified.

The electronics modules also carry a CSA mark that may be relied on by OEMs incorporating the meter module in their own CSA certified or UL listed product.

Limited Warranty

Davidge Controls warrants its products, if used in accordance with all applicable instructions, to be free from original defects in material and workmanship for a period of five years from the date of manufacture. If the product should prove defective in material or workmanship within that period, Davidge Controls will repair or replace the product, in its sole discretion. Service under this Warranty can only be obtained by your delivering or shipping the product (with all shipping or delivery charges prepaid) to: Davidge Controls, 583 Refugio Road, Santa Ynez, CA 93460. Davidge Controls will pay return shipping charges. Call Davidge Controls at (805) 688-9696 for a Return Material Authorization (RMA) before sending any equipment back for repair.

THIS WARRANTY DOES NOT APPLY TO NORMAL WEAR OR DAMAGE RESULTING FROM ACT OF GOD, ACCIDENT, MISUSE, ABUSE, OR NEGLIGENCE. SELLER MAKES NO EXPRESS WARRANTIES OTHER THAN THE WARRANTY EXPRESSLY SET FORTH HEREIN, EXCEPT TO THE EXTENT PROHIBITED BY APPLICABLE LAW. ALL IMPLIED WARRANTIES INCLUDING ALL WARRANTIES OF MERCHANTABILITY OR FITNESS ARE LIMITED IN DURATION TO THE WARRANTY PERIOD SET FORTH ABOVE AND THIS WARRANTY EXPRESSLY EXCLUDES ALL INCIDENTAL AND CONSEQUENTIAL DAMAGES. (Some states do not allow limitation on how long an implied warranty lasts, and some states do not allow the exclusion or limitation of incidental or consequential damages so the above limitations or exclusions may not apply to you. This Warranty gives you specific legal rights, and you may have other rights which vary from jurisdiction to jurisdiction).

Damage from lightning strikes, power surges, and improperly connecting the meter to the power source are not covered by the warranty.

Operating Instructions

After installation, the EZ Meter is simple to operate. You read the meter the same way you read the odometer in a car. The label on the front of the meter indicates the resolution of the display, either full kilowatt hours (kwh) or tenths of kwh. The label on the outside of the enclosure states the resolution. The label on the meter electronics module also states the resolution.

To charge a tenant for power used, subtract the meter reading at the beginning of the billing cycle from the meter reading at the end of the cycle and multiplying the difference by the rate per kilowatt hour.

You can clean the outside of the meter enclosure with a general purpose cleanser such as 409 or Fantastic if necessary. Do not use harsh bathroom cleaners or alcohol.

If the meter appears to operate erratically, it is probably because it measures each phase separately and flashes the green LED when each phase accumulates 1/100 kwh (or other resolution). The resolution may be different for the green LED, the display and the isolated output, if any, and will be noted on the label.

If you believe the meter is not measuring correctly, perform the test on page 7 and see the troubleshooting suggestions on page 8.

Understanding the Meter Label

The center section on the meter label reveals a lot of data about the meter, but some of it is in the language used by the metering standards.

Voltage - The range of voltages in which the meter will operate measured between line and neutral. If there is no neutral, it is the voltage line to line. For four wire delta meters, the voltage for the high leg is shown on the left for VAC #3.

Max Amps (CL) - The maximum load (in amps) on each leg that the meter can handle. This is also referred to as the meter class. Class 100 EZ Meters with serial numbers that start 003- are actually Class 200 amp meters but are labeled as 100 amps to comply with regulations that require the meter class to match the maximum load.

Test Amps (TA) - This is another term from the standards and is set by the manufacturer, usually at 15% of the class rating.

Kh - This is the abbreviation for the Meter Constant, the number of watthours recorded in one indication of the meter. On EZ Meters, the indication is a flash of a green LED. For clarity, the label also indicated the value of one flash in kilowatt hours (KWH).

Kr- The Register Constant is the number of flashes of the LED for one indication of the display counter. The label also displays the resolution of the display in KWH.

Kiso - This is not a term from any standard, but indicates the number of flashes of the LED for each pulse generated at the isolated output terminal(s). Also displayed is the KWH value of each pulse.

Short TEST to COMN - Some meters have a TEST terminal and Test mode can be activated by installing a short wire between the TEST and COMN terminals. As long as that wire is in place, the meter will indicate at the resolution shown on the label, usually Kh=10 or 0.01 KWH per flash of the LED and increment of the counter.

Accuracy Certification

All EZ Meters are guaranteed to meet the ANSI C12.1 standard for electric meters. This standard allows an error of up to 1% when new and 2% when field tested.

In California, Maryland and Canada, meters are regulated by the government when used for revenue billing. Contact the local Weights and Measures office. Special meters are available for California that meet the state's security requirements (all EZ Meters exceed California's accuracy requirements).

A Note for California Users

All meters used in California for which a charge is made for power must have been inspected by a Weights & Measures inspector and placed in service by a Licensed Service Agent or a Weights & Measures official. The meter must be reinspected by Weights and Measures every ten years. It is a misdemeanor to fail to do this. See the ezmeter.com for more on these requirements.

Installation Instructions

These instructions are for meters whose model number begins with a number, not a letter.

The EZ Meter consists of an electronics module, one or more current transformers (CTs), one or two electro-mechanical display counters and an enclosure that holds from one to 24 meters. If the meter will be mounted outside in direct sunlight, be sure to order a UV resistant enclosure or paint the standard enclosure. The CTs and display counters may be mounted in the same enclosure or mounted in a remote location. A common practice is to mount the CTs in a breaker panel and mount everything else in a separate adjacent enclosure. A circuit breaker rated at 200 amps or less should be installed before the meter. Be sure no one will be able to turn off the breaker and defeat the meter.

Installing the NEMA4X Enclosure: Use the metal brackets provided to mount the enclosure in a suitable location. Drill a hole anywhere in the side or back of the enclosure for a conduit to connect to a breaker panel or disconnect box in compliance with local electrical codes. After the meter has been installed and tested, secure the cover using the screw or small padlock provided. You should also label each display counter with the unit name or number.

Installing the NEMA1 plastic enclosure: This enclosure was designed to be recessed into a sheetrock wall. Cut a 6" square opening in the sheetrock adjacent to a stud. Drill a hole in the back or side of the enclosure for a conduit. Install the CTs and make the electrical connections as described below before installing the enclosure in the wall. Fillister head screws with holes are provided so that the cover may be secured with a seal if required.

Installing the CTs: If you are using **solid core CTs**, you must turn off the power to begin your installation. Disconnect one end of the wire (or wires) with the load to be measured and pass it through the center of the CT and reconnect the wire(s) where it was attached before. Connect the two wires coming out of the CT to the appropriate

terminals on the electronics module. Begin connecting CTs to CT #1 and continue until all the CTs for that meter are installed. The direction of the current flow is not important unless you are installing multiple CTs on one leg or you are installing a bidirectional meter.

You can **install more than one CT on each leg** if you need to. You might need to if you were measuring several circuits in one breaker panel and the wires were not long enough for all to go through one CT or if you wanted to measure power being used in two separate breaker panels. Just be sure all the wires on each leg go through CTs that are connected to the same terminal on the meter and that the direction marks on the CTs are aligned the same. Multiple CTs should be connected in parallel.

If you run **more than one wire through a CT**, be sure that the current flow is the same direction for all wires and that all the wires are the same leg (phase). That means there should be no voltage variation between the wires (if you touched them together, they would not spark). Failure to do so will cause the power flowing in one wire to be subtracted from the power flowing in the other wire instead of being added to it.

The CT wires can be extended if needed. We have tested them at 500 feet and they can probably be extended even further. If the line resistance is much over one ohm, accuracy of the meter will be affected, especially at high phase angles. Be sure to install the CT wires in conduit. Connections should either be soldered or made with gel filled wire nuts. Any resistance in the connection will cause the meter to read lower than it should. The wire used should meet local codes for insulation. Any size wire from 22 AWG to 12 AWG may be used. #18 is suggested.

You can install **split core CTs** without disconnecting the wire. If you have to install them without turning off power, connect the wires to the meter before securing the two parts of the CT over the wire carrying the load. Be sure to secure the two parts of the CT so it cannot come apart.

Do not mix split core and solid core CTs on the same meter.

WARNING

Hazardous voltages exist in CT wires when they are not connected to meter and current is flowing through wire passing through the CT. Wire nut the CT wires together if you must remove the meter and leave the CTs in place.

Electrical Connections: You need to provide a voltage reference for each phase of the power you are metering plus connect the neutral to the meter as well. The voltage ranges printed on the electronics module label (after CT#1 etc) refer to the voltage between neutral and that terminal and indicate what meter works with what electrical system. The voltage associated with the meter name is the most commonly used voltage in the range.

You can use any size wire from 28 AWG to 12 AWG. Be sure insulation meets local codes. Each phase should be protected by a circuit breaker or fuse of 200 amps or less. For safety, a switch or circuit breaker must be installed between the meter and the mains power source. It shall be in close proximity to

the meter and within easy reach of the operator and shall be marked as the disconnecting device for the equipment.

Display Connections: The electro-mechanical counter comes already connected to the meter. If you purchased an OEM version of the product, connect as shown in the diagram below. If you have a dual output meter, DISP1 is matched with CT#1 and VAC #1 while DISP2 is matched to the remaining CT(s).

Isolated Outputs: If you have a pulse output meter, connect the two wires from the pulse counting equipment to ISO- and ISO+ respecting polarities. The grounded terminal of the pulse counting device needs to be connected to the ISO- terminal on the meter. If you have a dual output meter, connect one set to ISO- and ISO1 and the other set to ISO- and ISO2. They correspond with DISP1 and DISP2.

METER INSTALLATION DIAGRAM

Ignore terminals on diagram that are not on your meter.
DISPL will be DISP2 and ISO+ will be ISO2 on dual output meters

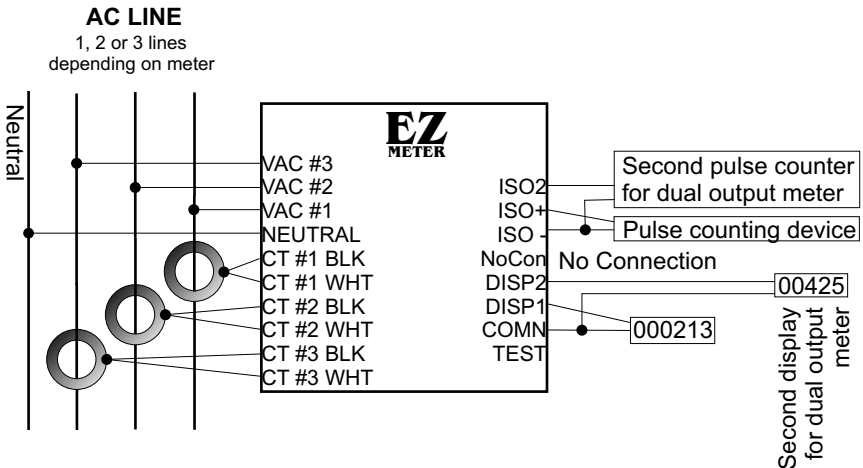

Instructions and Specifications for Specific EZ Meter Models

Bidirectional Meters: All the single output meters described below are available as bidirectional meters. They are used in net metering systems or wherever current flow in both directions must be monitored separately. The counter connected to the DISB terminal will display power that flowed in the direction of the dot on the CT, while power that flowed in the other direction will be displayed on the other counter (DISA). In the diagram on page 5, DISA replaces DISP1 and DISB replaces DISPL. The isolated outputs labels work the same way.

Model 401x - Yosemite: 3 Wire, 120V to neutral, 240V line to line. If used for a single 120 volt service, connect to the #1 terminals.

Model 402x - Denali: Dual 2 Wire, 120 volts to neutral. This meter handles two separate 120 volt services. The service connected to 90-140 VAC #1 and CT #1 will register on the display connected to DISP1 and COMN. The second service is connected to the #2 terminals. If only one service is connected, connect to the #1 terminals. This meter can be connected as a Yosemite meter. Short DISP1 and DISP2 together and use just one counter.

Model 411x -Yellowstone: 4 Wire, 3 phase Wye, 120V to neutral, 208V line to line. If used for a single 120 volt service, connect to the #1 terminals. It is also okay to use with only two elements connecting to the # 1 and #2 terminals.

Model 412x - Olympic: Dual 120/240 volts to neutral. The Olympic is essentially a Yellowstone meter with a second display. The 120 volt service connected to the #1 terminals outputs to DISP1 while the 240V service connected to the #2 and #3 terminals outputs to DISP2. The meter can be used for a 208V three phase system by shorting DISP1 and DISP2 together. If used for a 240 volt service without a 120 volt load, connect power to VAC #1 to power the meter.

Model 441x - Sequoia: 2 Wire, 120 volts to neutral. Meters capable of handling two CTs are frequently shipped with one CT instead of a meter capable of only handling one CT. If you receive one of these, connect to the #1 terminals and ignore the others.

Model 511x - Gettysburg: 4 Wire, 3 phase Wild Leg, 120/120/208V to neutral, 208V line to line. The Wild Leg is also known as the Stinger leg in some parts of the country. Connect the two 120V legs to VAC #1 and VAC #2 and connect the 208-240V leg to VAC #3. Caution - Doing this wrong will burn up the meter.

The models listed below have not been tested by CSA and have no safety certification.

Model 141x -Biscayne: 2 Wire, 220 volts to neutral. Connect voltage to VAC #1 and VAC #2 terminals. Put the CT on the #2 wire.

Model 241x - Glacier: 2 Wire, 240 volts line to line. Connect one hot wire to VAC #1 and the other to VAC #2. Either load wire can go through the CT which is connected to the CT #1 terminals. Do not use this meter if 120V to neutral loads exist.

Model 201x - Zion: 3 Wire, 3 phase delta, 208 volts line to line. The Zion meter is accurate only when a relatively balanced load is applied to the three phases. Before installing the meter, use a clamp-on ammeter to determine the two most equally balanced legs. Run these wires through the CTs and connect to the #2 and #3 terminals. Connect the other hot wire to VAC #1.

Model 311x -Lassen: 4 Wire, 3 phase Wye, 277V to neutral, 480V line to line. Follow the general instructions above. If you have special ordered a dual counter meter, it will work the same as the Olympic meter with higher voltage. Do not attempt to connect to a 480 volt delta without a neutral.

Model 611x - Shenandoah: 4 Wire, 3 phase Wild Leg, 240/240/440 volts to neutral, 440 volts line to line. Connect the same as the Gettysburg meter, except higher voltage.

Testing the Installed Meter

The Test Jumper. Meters whose model number ends with /CA do not have a TEST terminal. The green LED flashes every 0.01 kwh on these meters. On all other meters, you can connect a wire between TEST and COMN which changes the resolution to 0.01 kwh while the wire is in place.

After the meter has been installed, it is a good idea to turn power on the system and check to see that the meter was connected to the power line properly. This can be determined easily by looking at the red LED in the top, center portion of the label on the electronics module. This LED should glow a bright red whenever power is on.

If the meter is receiving power, the next step is to verify that the meter is operating properly. You will need a hair drier or other small appliance that uses approximately 1500 watts or more to be able to do the test in a reasonably short time. Since the meter measures each phase separately, you will need to test each phase individually.

Without getting into phase angle, resistance and impedance measurements, the following formula will tell you how many seconds it should take to count 0.01 kwh:

$$\text{SECONDS} = 4,320,000 / \text{VOLTS} / \text{WATTS}$$

where VOLTS is the AC voltage measured at the meter (it is important to measure this as

variations up to 10% are common) and where WATTS is the wattage shown on the nameplate of the appliance providing the load.

For example, a 1500 watt hair dryer on 120 volts will use 0.01 kwh in $4,320,000 / 120 / 1500$ or 24 seconds.

To set the meter in test mode, install a short piece of wire between the terminals marked **TEST** and **COMN** on the meter. This will cause the meter to count every 0.01 kwh instead of every 0.1 kwh. If your meter has a '/CA' suffix in its model number, you can eliminate this step. The green LED flashes every 0.01 kwh.

To check a 120 volt service, turn on your heater and begin timing when the mechanical counter advances the first time. The counter should advance again about 24 seconds later (or whatever time you figured using the formula above for the load you are testing with.)

Be sure to remove the wire from the **TEST** and **COMN** terminals after testing the meter.

If you have several meters but don't have a voltage meter, you can test several meters and if they all use the same number of seconds, you can assume the meters are working okay even if the time observed is different than the calculated time. This test will also correct for variation in the actual number of watts used by the appliance versus the number shown on the name plate.

General Specifications

Operating Temperature: 14°F (10°C) to 140°F(60°C)

Storage Temperature: -40°F (-40°C) to 160°F (71.1°C)

Humidity: Humidity 80% for temperatures up to 31°C decreasing linearly to 50% relative humidity at 40°C

Max Operating Altitude: 9000 ft (2743m) MSL

Power Usage: less than 2 watts

Frequency: 50-60 Hz

Nominal Voltage: 110 VAC to neutral

Voltage Tolerance: ±20% or as on meter label

Current Tolerance: Up to rated load +10%

Max load currents per element by model number where

x is the number in the model numbers that follow:

x=0, 200 amps; x=1, 100 amps, x=3, 20 amps,

x=5, 500 amps, x=6, 1500 amps, x=7, 750 amps.

ISO Pulse: 50 ms contact closure every pulse.

Trouble Shooting

Try the following steps if the meter does not work. A simple AC voltmeter will make trouble shooting much easier.

No Red LED

Be sure that line and neutral wires are connected properly and that power is turned on. Check this with your voltmeter by measuring the voltage between the Neutral and VAC #1 terminals. The voltage should fall in the range specified for the meter. If it does not, you have not connected it properly, the power is not turned on, or you have the wrong meter for your electrical system. Check the voltage between the neutral (usually white wire) and ground. This voltage should be close to zero.

No Green LED

The green LEDs are normally off. They flash briefly when the mechanical counter advances or every 1/100 kwh depending on the meter model.

Green LED flashes but Counter does not change

The meter is correctly detecting the usage of power but the mechanical counter is not moving. Be sure the counter is connected properly with one wire going to **COMN** and one wire going to **DISPL**. When the green LED flashes, the mechanical counter should advance. With 2-in-1 meters, when the top green LED flashes, the counter connected to **DISP1** should advance indicating current measured with the transformer connected to the CT #1 terminals. When the bottom green LED flashes, the counter connected to **DISP2** should advance.

If the counter is properly connected and does not advance when it should, replace the counter with a different one.

Green LED Flashes too often

The most common cause of inaccurate meters is a poor neutral connection, either at the meter, at the panel, or where it connects to ground. Check your neutral. If a CT wire is shorted to neutral or ground, it will also cause a very high reading.

The time is wrong when doing the accuracy check.

Be sure all the terminals are wired correctly and screwed down tightly.

Be sure a jumper wire is installed between the **TEST** and **COMN** terminals (not necessary for Calif. Approved meters).

Be sure the hair dryer or other electrical load is plugged into the proper circuit and that it is the only thing drawing current through this meter.

Be sure the wire to the hair dryer only passes through the current transformer one time and that the neutral wire does not pass through it.

I have several meters and one appears to be reading lower than the others.

If you think one of the meters is reading low, swap the meter with one that appears to be reading right.

Still doesn't work

Check at <http://www.ezmeter.com> for more trouble shooting suggestions or call Tech Support at (805) 688-9696 between 9:00AM and 5:00PM Pacific Time, Monday through Friday. Each meter is covered by a five year limited warranty (see page 2). There is a charge for meters that are returned for repair that are not defective.

EZ
METER

Davidge Controls
1-805-688-9696
583 N Refugio Road
Santa Ynez, CA 93460
www.ezmeter.com
support@ezmeter.com